

THIS DRAWING IS UNPUBLISHED. RELEASED FOR PUBLICATION
 © COPYRIGHT BY TYCO ELECTRONICS CORPORATION. ALL RIGHTS RESERVED.

LOC	DIST	REVISIONS			DAP		
G	14	P	LTR	DESCRIPTION	DATE	DWN	APVD
		E2		REV PER ECR 05-007745	28JUL05	JR	MS

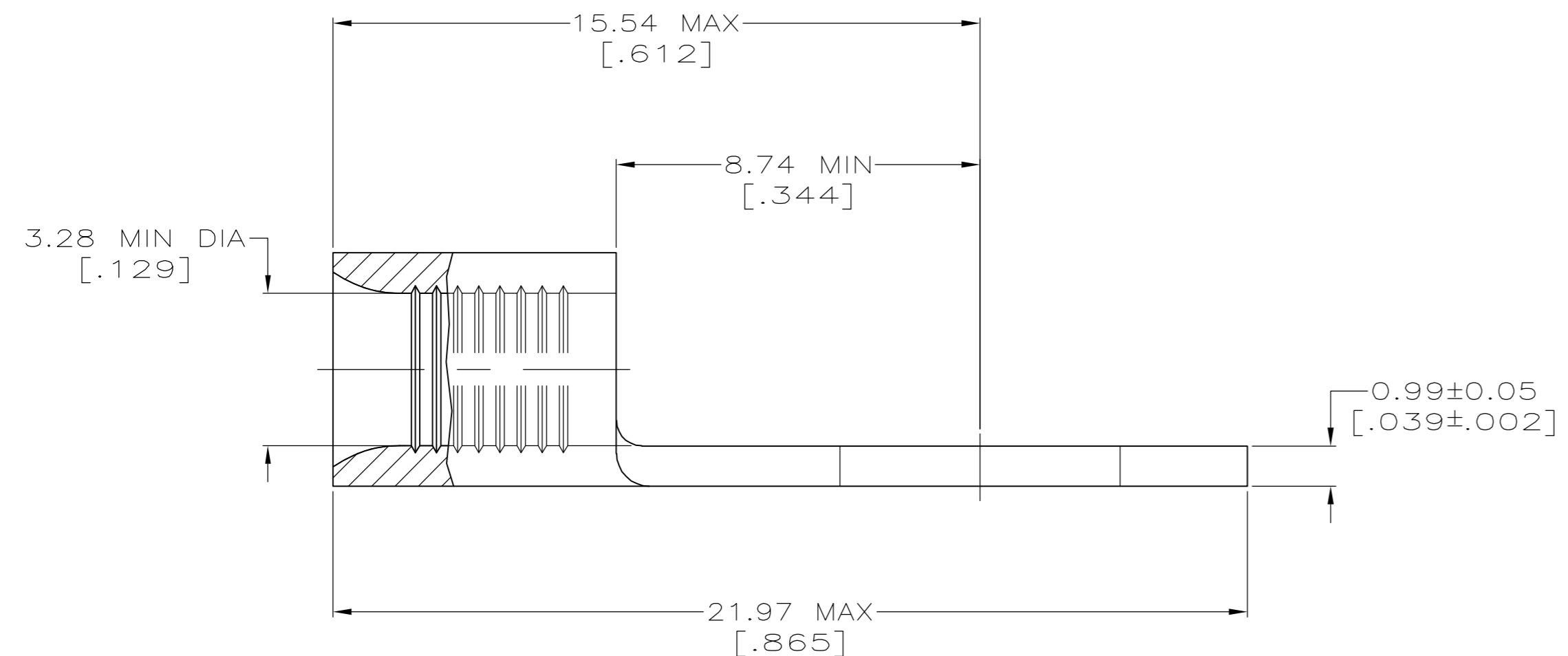
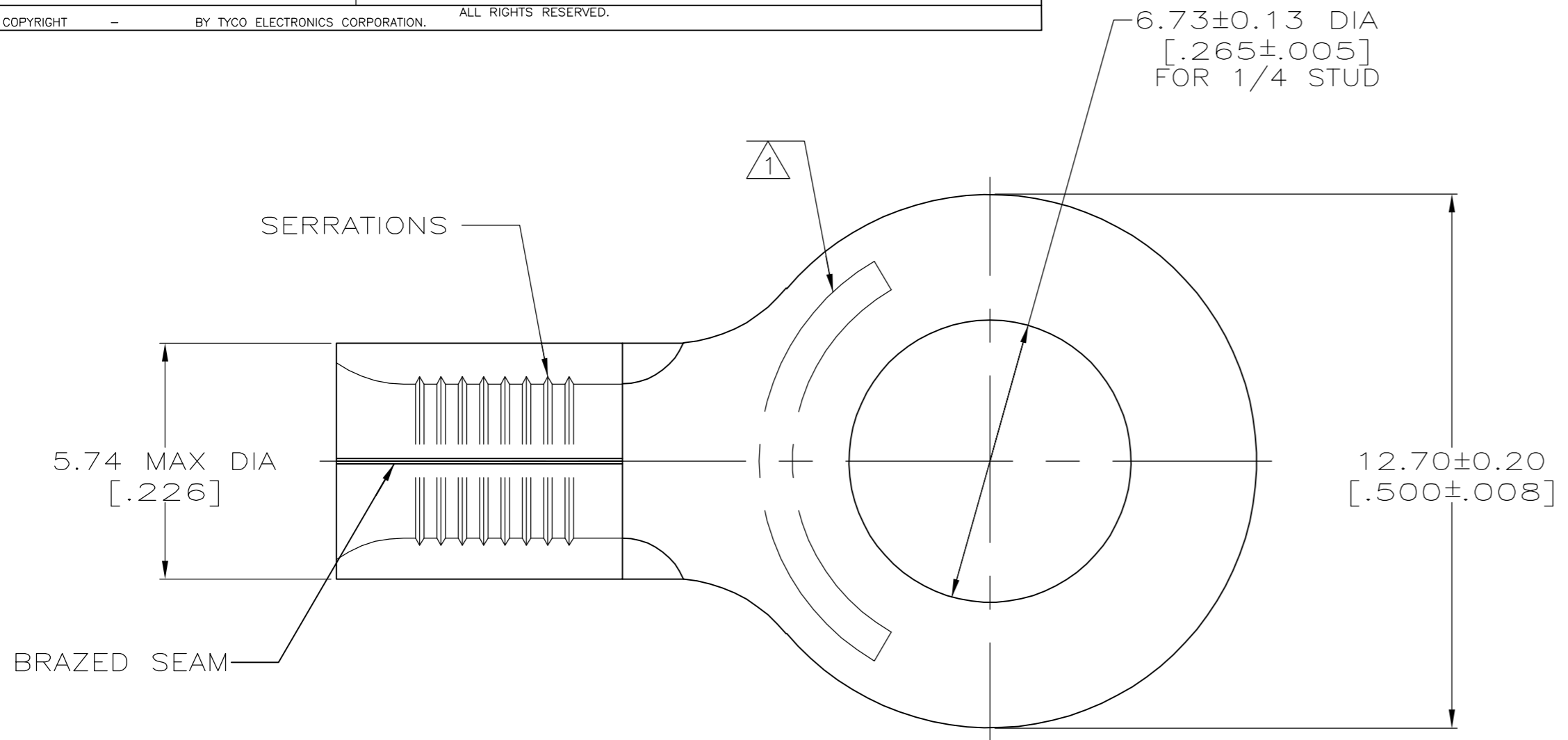

AMP WIRE RANGE	Listed FILE E13288	LR7189 Certified
12-10 AWG SOLID OR STRANDED	12-10 AWG STRANDED	12-10 AWG SOLID OR STRANDED

- 1 STAMP AMP 12-10* APPROX AS SHOWN
- 2 MATERIAL: COPPER PER ASTM B-152, ANNEALED
- 3 TIN PLATE 0.00254 [.000100] MIN THK PER ASTM B-545.
- 4 GOLD PLATE 0.00127 [.000050] MIN THK PER MIL-G-45204 OVER NICKEL PLATE 0.0076 [.000030] MIN THK PER QQ-N-290.

FINISH	QTY	PACKAGE TYPE	PART NO.
4	----	LOOSE PIECE	35772-1
3	25	LOOSE PIECE, BAG	8-35772-5
3	50	LOOSE PIECE, BOX	8-35772-2
3	2500	ON TAPE	2-35772-1
3	----	LOOSE PIECE	35772

AMP INCORPORATED CUSTOMER SERVICE SYSTEMS		MAX RECOMMENDED OPERATING TEMPERATURE: 170°C
FOR ADDITIONAL PRODUCT INFORMATION OR COPIES OF DRAWINGS AND TECHNICAL DOCUMENTS	PRODUCT INFORMATION CENTER 1-800-522-6752	VOLTAGE RATING: N/A
FOR APPLICATION TOOLING INFORMATION	TOOLING ASSISTANCE CENTER 1-800-722-1111	CIRCULAR MIL AREA: 2.62-6.64mm² [5,180-13,100] SOLID OR STRANDED
FOR ORDER ENTRY	1-800-526-5142	THIS DRAWING IS A CONTROLLED DOCUMENT FOR AMP INCORPORATED. IT IS SUBJECT TO CHANGE AND THE CONTROLLING ENGINEERING ORGANIZATION SHOULD BE CONTACTED FOR THE LATEST REVISION.

THIS DRAWING IS A CONTROLLED DOCUMENT.		DWN TA BRINKMAN 3-17-93	tyco Electronics		Tyco Electronics Corporation Harrisburg, Pa 17105-3608	
DIMENSIONS: INCHES	TOLERANCES UNLESS OTHERWISE SPECIFIED:	CHK DA PATTERSON 3-17-93	NAME JL MECKEY 3-17-93			
	0 PLC ± - 1 PLC ± - 2 PLC ± - 3 PLC ± - 4 PLC ± - ANGLES ± -	APVD JL MECKEY 3-17-93	PRODUCT SPEC APPLICATION SPEC			
MATERIAL - 2	FINISH SEE TABLE	WEIGHT -	SIZE A2	CAGE CODE 00779	DRAWING NO C=35772	RESTRICTED TO -
CUSTOMER DRAWING			SCALE 8:1	SHEET 1 OF 1	REV E2	